



but does always signify the presence of other people, Lauren Berlant

solidarity needs to be a condition otherwise this is all just philosophy (Miriyam Aouf)

bounded beings *abstraction*

**ACCOMPLICES
NOT ALLIES**

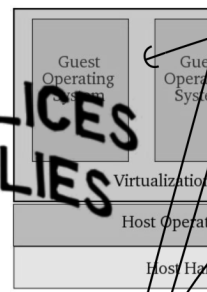

Abolishing the ally industrial complex, an indigenous perspective

dispossession *relationship* *combined*
sovereign

“(It) is not about a relationship between the tangible and the intangible, it is about the duration of a relationship, trust, and a way of structuring the future in terms of liability and responsibility” (The design of software, Erickson & K...

*technological
nonsovereignty*

attachment

dependency *sovereign*

≠

One need not... nor imagine s... to be... in... of states and...
Do It

“This is a rhythm of endurance, of surging forward and withdrawing. It is not a rhythm of endless becoming nor of staying put; it is making the most of the “hinge,” of knowing how to move and think through various angles while being fully aware of the constraints, the durability of those things that are “bad for us”.”
 (Improvised Lives, AbdouMaliq Simone)

Klein Bottle topology:
 Inside is outside is inside
 is outside is inside is
 outside is inside is outside
 is inside is outside is inside

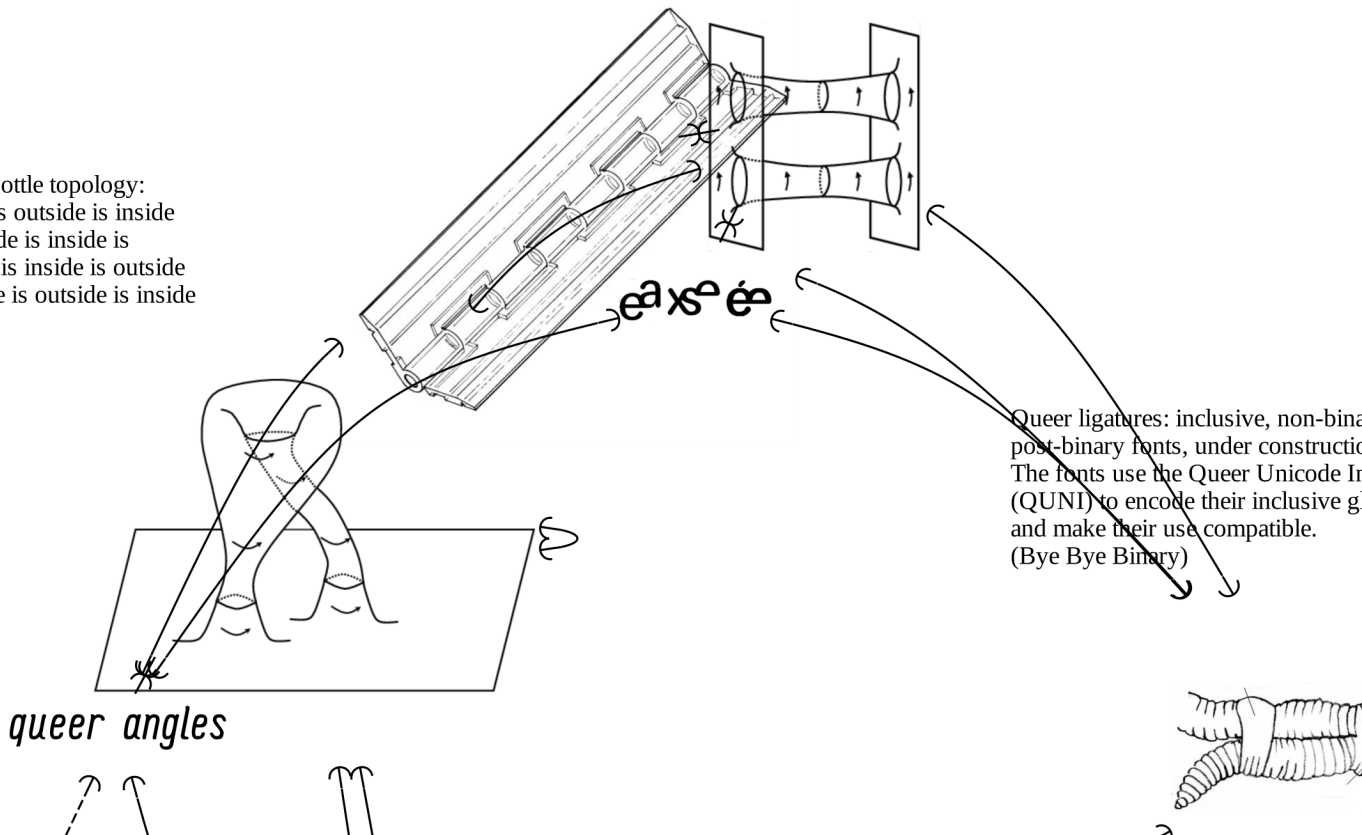

Lygia Clark, Caminhando [Walking] (1964)

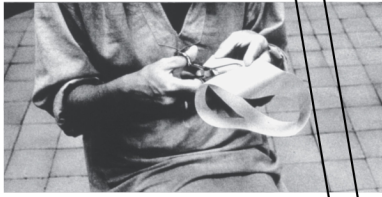

NEW 3300 "BASIC" Programming System \$10,000

...an interactive system for only \$10,000...
...with a compact design...
...the most user-oriented...
...with over one million...
...WANG

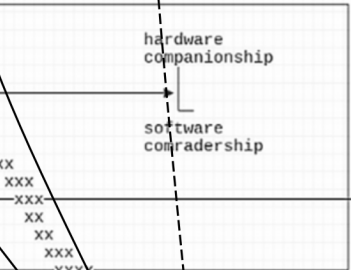

insurgent intersectionality

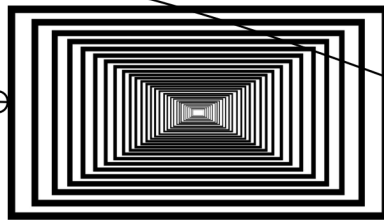

institutional manoeuvres

digital depletion

outsourcing

queer angles

Lygia Clark, Caminhando [Walking] (1964)

Lygia Clark, Caminhando [Walking] (1964)

© 1964 Digital Equipment Corporation. All rights reserved. Reproduction in whole or in part without written permission is prohibited.

time sharing

parallelism

software companionship

solidarity

The student card, the username and password, the name.surname@institution.edu email, the DigiLocker, the eduroam account, the Adobe license, the Zoom login, the card to pay at the canteen, the library card, the...
unbundling

pointing to relationality...
use of injury

ary,
on.
initiative
lyphs

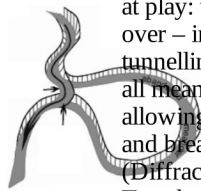

“We might imagine re-tuning as a multiplicity of processes, such as the kinds earthworms revel in while helping to make compost or otherwise being busy at work and at play: turning the soil over and over – ingesting and excreting it, tunnelling through it, burrowing, all means of aerating the soil, allowing oxygen in, opening it up and breathing new life into it”
(Diffracting Diffraction: Cutting Together-Apart, Karen Barad)

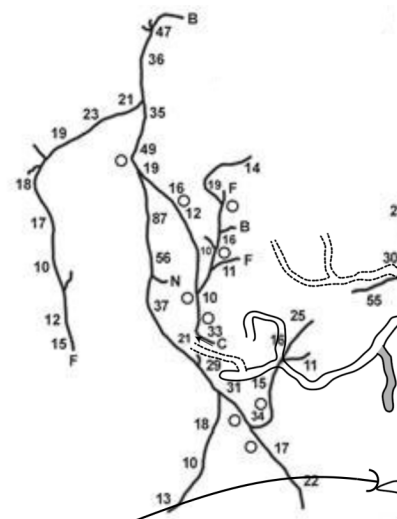

burrowing

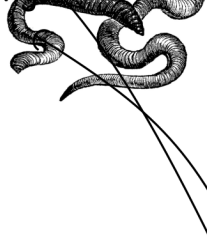
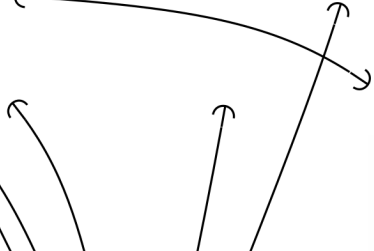
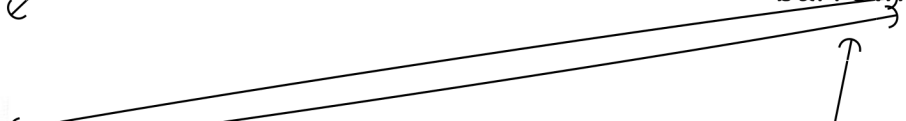
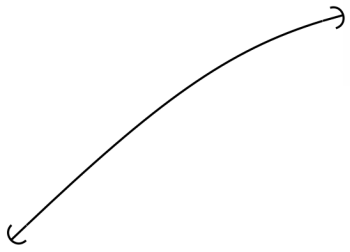
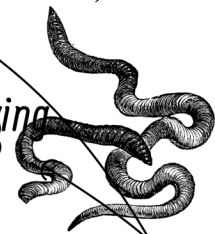

eighty



the potential
of sovereignty

Thursday June 1, 2023

Agree not merely to the right to difference, but, carrying this further, agree also to the right to opacity that is not enclosure within an impenetrable autarchy but subsistence within an irreducible singularity. Opacities can coexist and converge, weaving fabrics. To understand these truly one must focus on the texture of the weave and not on the nature of its components. (For Opacity, Édouard Glissant)

vulnerability

“If The Commons claim sounds like an incontestably positive aim, I think of it more as a tool, and often a weapon, for unlearning the world, which is key to not reproducing it” (On the inconvenience of other people, Lauren Berlant)

#queer_is_stateless

undercommons

opacity

The Common

affective infrastructure

state

We say **no**; **no** to this disposal of **no**.
We raise our voices in saying **no** to
this violence and injustice. **No** can
become a form of critical refusal, as
Angela Davis might suggest; **no** that
involves commitment, **no** that requires
time and work as we grapple to
understand the system from which an
injustice gapes like a hole; **no** as part
of a project of counter-knowledge, to
counter with knowledge; **no** as a struggle
not to reproduce injustices that exist.
(**No**, Sara Ahmed)

no

counterlog(ist)ies

≠

affect

the anti-state state

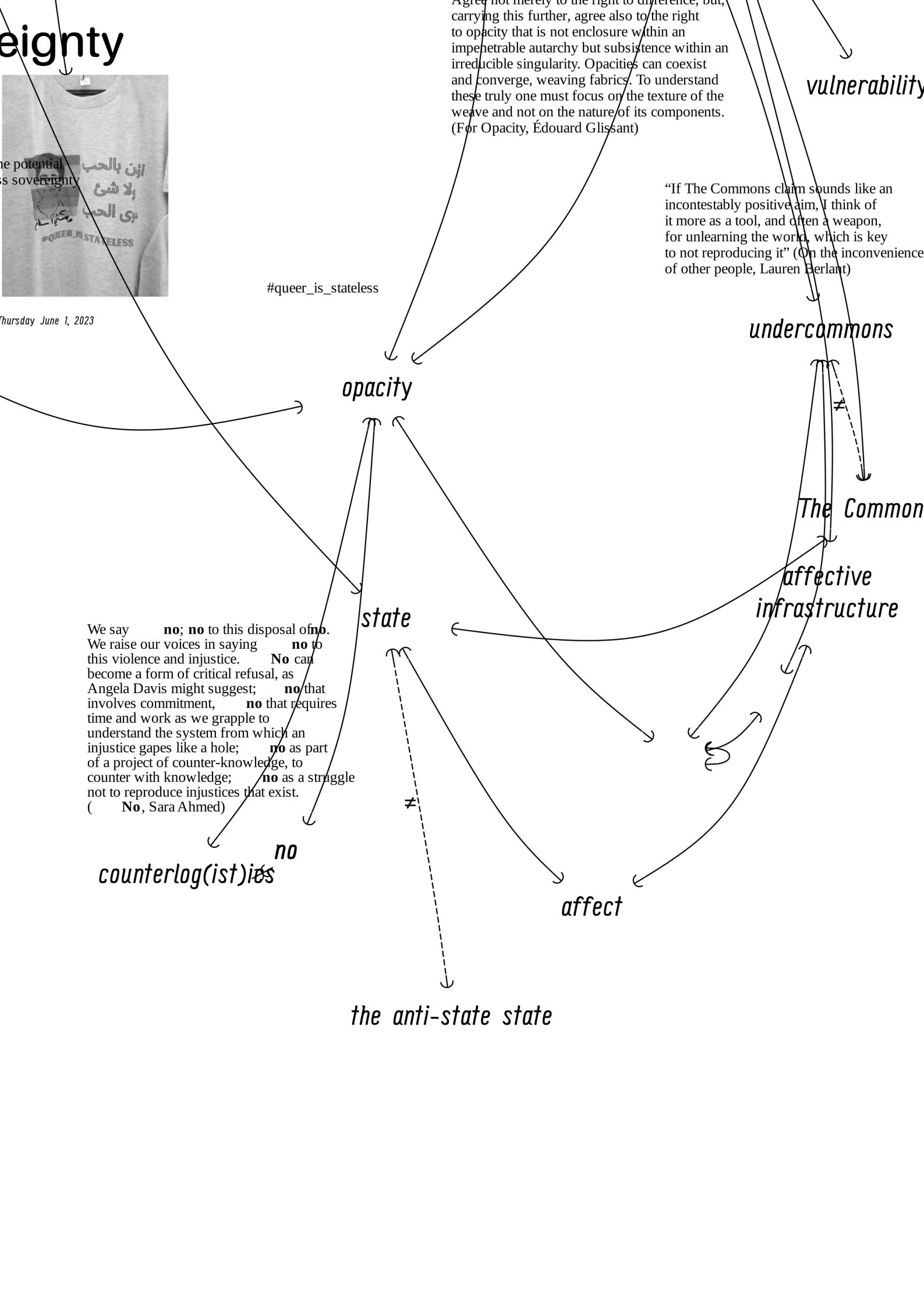



“In the wormhole the worm creates an infrastructure to hold itself in the world: the hole fits the worm, but only as it moves.” (On the inconvenience of other people, Lauren Berlant)

Diagram of the crystallographic structure of a zinc metallo-beta-lactamase from bacillus cereus. Folding is part of the dynamics of proteins. Proteins are not strictly static objects, but rather populate ensembles of conformations. Transitions between these states occur on a variety of time scales.

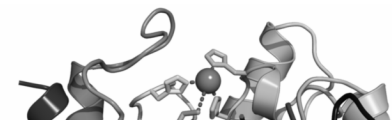

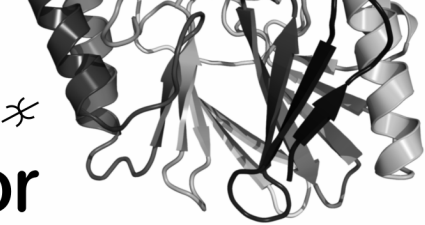

or
he
ns

Active helical waves produced by the motion of individual worms facilitate collective tangling and ultrafast untangling.

friction

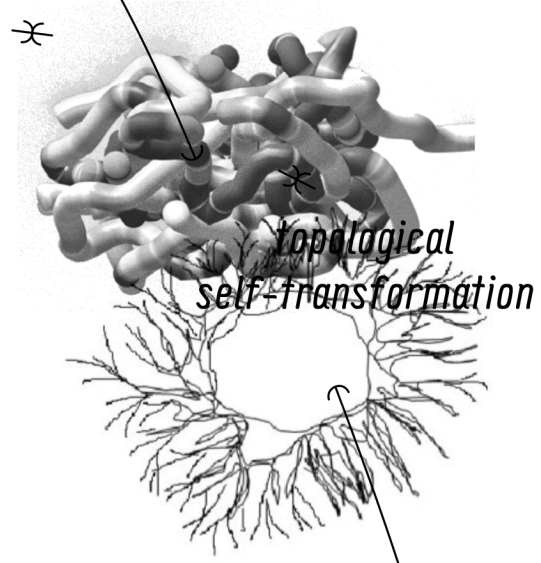

Mycellium, circular cascading rootstructure (decentralized but hierarchical)

Paranodal is a term that conceptualizes that which is other to — or an alternative to — a network configuration. (...) the paranode is the space that networks leave out, the negative space of networks, the noise between nodes and edges. (Zach Blas, Contra-Internet ← → Ulises Ali Mejias, Off the Network)

Throwing worms at Paul Baran, On Distributed Networks (1964) (CCRURU)

onal
ude

-called
sterility

imes of a sterility,
ove from being
ndomment (...)
— who refuse to bear
ism's stark utopia,
ement, the violence
on Geography: Essays
h Wilson Gilmore)

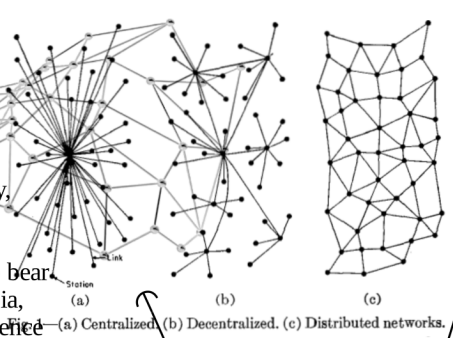

A trembling thought is not a frightened thinking, nor a fearful or hesitant one, it is the thought that refuses systems that are rigidly self-contained, and that believes that the world trembles, physiologically, in its becoming, in its suffering, in its oppositions, in its massacres, in its genocides, in its pleasures. (Poetics of relation, Édouard Glissant)

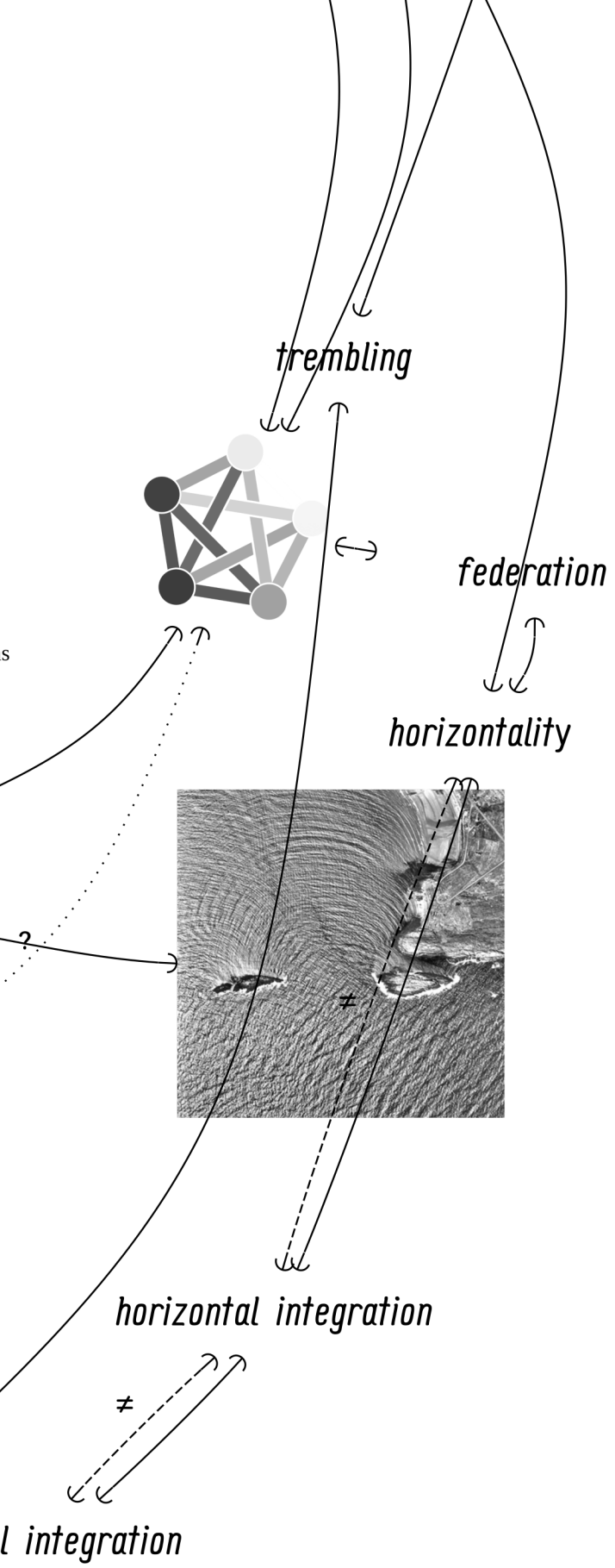

“vulnerability is [not] reducible to its injurability.”
 (Judith Butler ↔ Jennifer C. Nash)

7

S