

*Freedom*

↗

solidarity needs to be a condition

One need not be a nationalist,  
nor imagine self-determination  
to be fixed in modern definitions  
of states and sovereignty, to  
conclude that, at the end of  
the day, freedom is a place.  
(Abolition Geography: Essays  
Towards Liberation, Ruth Wilson  
Gilmore)

virtu

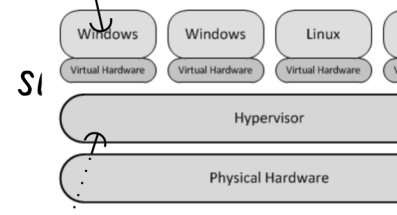

*technological  
nonsovereignty*

*containerization*

*data dispossession*

*abstraction*

out

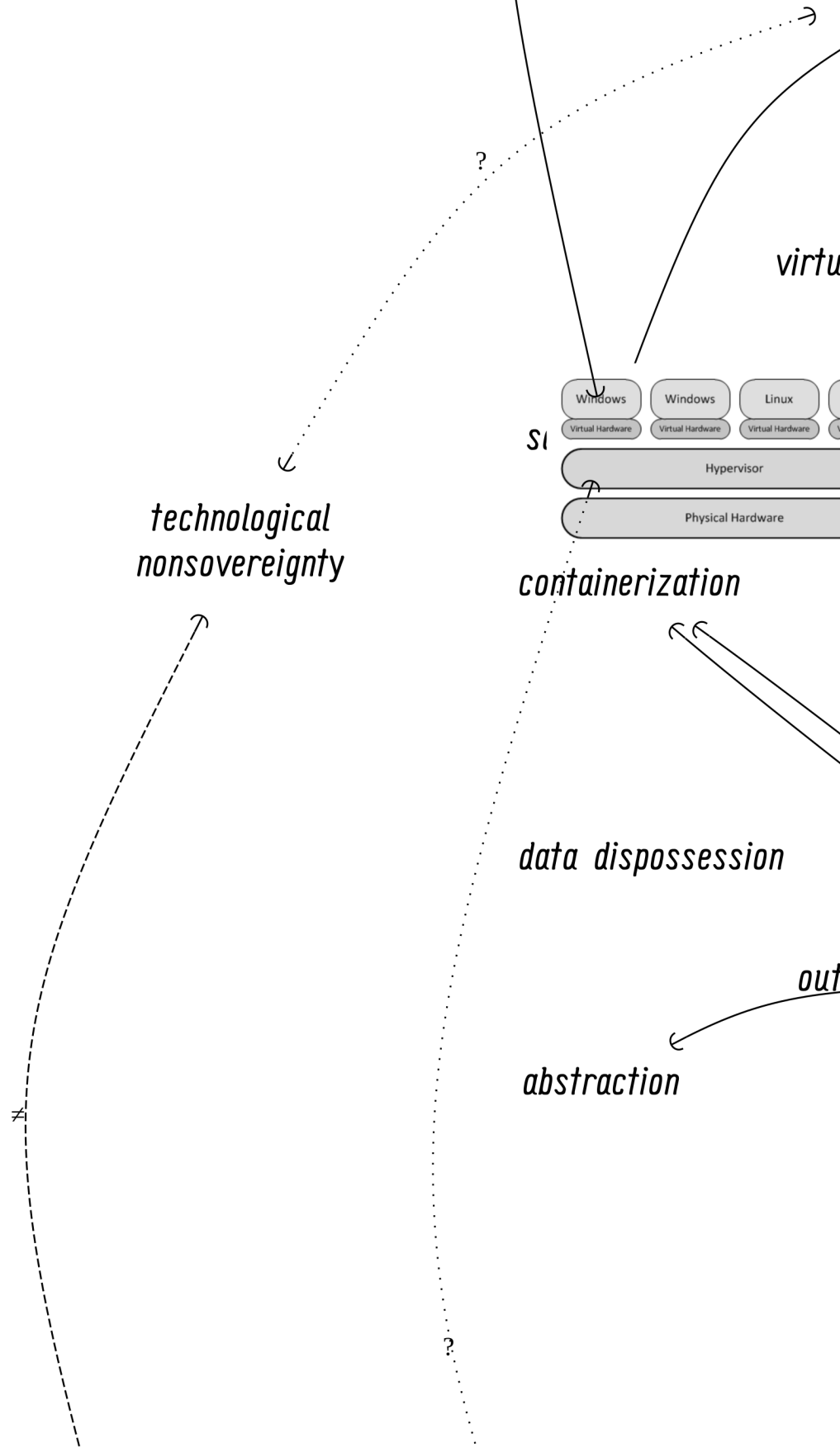

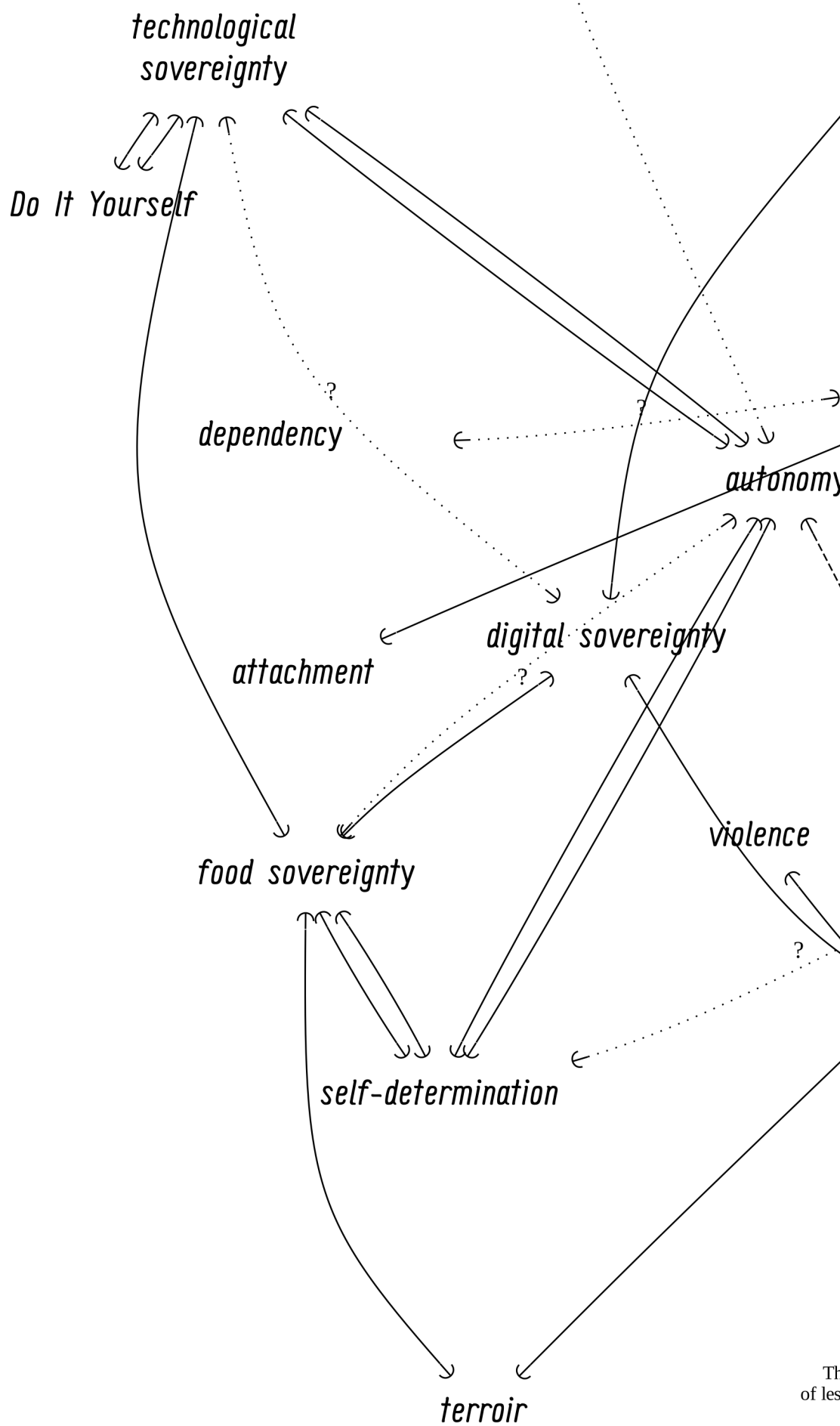

*the anti-state state*

e

conditions for connectivity

productive connectivity

reproductive networking

software companionship

time sharing

Cell for Digital Discomfort, diagram of "Conditions for Connectivity," 2021, digital rendering of an abstract plain-text diagram.

"The 3300 is a time sharing mini-computer system for only 1/4 the cost of subscription services or other in-house time sharing systems. That, in itself, is very therapeutic"



low cost group therapy

WANG'S NEW 3300 The First "BASIC" Time Sharing System Under \$20,000

WANG LABORATORIES, INC. 3800 Central Expressway, Redwood City, CA 94063

The 3300 is a time sharing mini-computer system for only 1/4 the cost of subscription services or other in-house time sharing systems. That, in itself, is very therapeutic. And one experience about communicating with a computer can be obtained by BASIC. The popular conversational language, ideal for business and education. It's simple to get started with. And BASIC is available on just one terminal if you like. Then add hardware as needed to accommodate up to 10 users or 100 terminal capacity. It's truly a real experience.



intersectionality

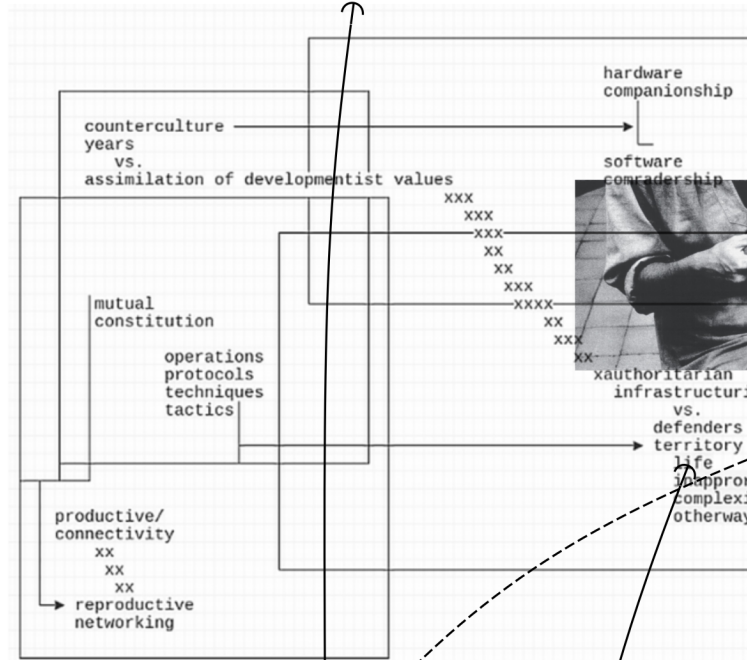

solidarity

on otherwise this is all just philosophy (Miriyam Aouragh)

# relational sovereignty

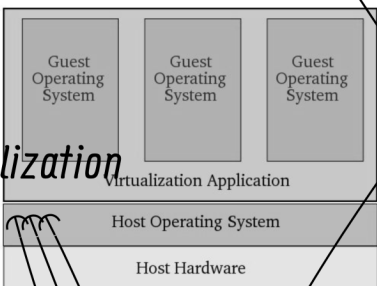

Miriyam Aouragh,  
Layal Ftouni,  
Maayke Botman,  
Sruti Bala

mutual  
Constitution

paradigm

Virtualization is a process that allows a computer to share its hardware resources with multiple digitally separated environments. Each virtualized environment has its own experience of nonsovereign relationality within its allocated resources, such as memory, processing power, and storage. (AWS)

Inconvenience is another way of pointing to the experience of nonsovereign relationality. It does not always produce a sense of injury but does always signify the pressure of what to do with coexistence. (On the inconvenience of other people, Lauren Berlant)

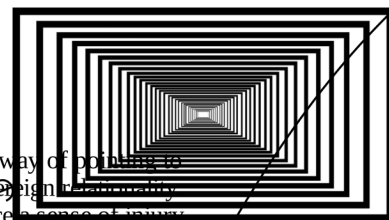

“(It) is not about a relationship between the tangible and the intangible, it is about the fixed duration of a relationship of trust, and a way of structuring the future in terms of liability and responsibility”  
(Erickson & Kelty)

Preparing a server migration

radical  
relationality

The Cloud

Warning: the bounding boxes of some nodes touch - falling back to straight line edges failed at node 0[1]  
stdp: maze.c:313: chksgraph: Assertion 'np->cells[1]' failed. Aborted (core dumped)

WHAT IS CLOUD

- \* smart phone / vint
- financialized / is
- \* service / a / geo / om / software

experiments w. transcription broadcasts?

local working meeting

we have a session

- reduce filesize
- reduce load time
- reduce generation
- reduce generation

technological nonsovereignty

Freedom

relational sovereignty

One need not be a...  
to be fixed in...  
of a...  
the day, freedom...  
of a...  
via...  
attachment

solidarity needs to be a condition otherwise this is all just philosophy (Miriyam Aouragh)  
Inconvenience is another way of pointing to the experience of nonsovereign relationality. It does not always produce a sense of injury but does always signify the pressure of what to do with coexistence. (On the inconvenience of other people, Lauren Berlant)



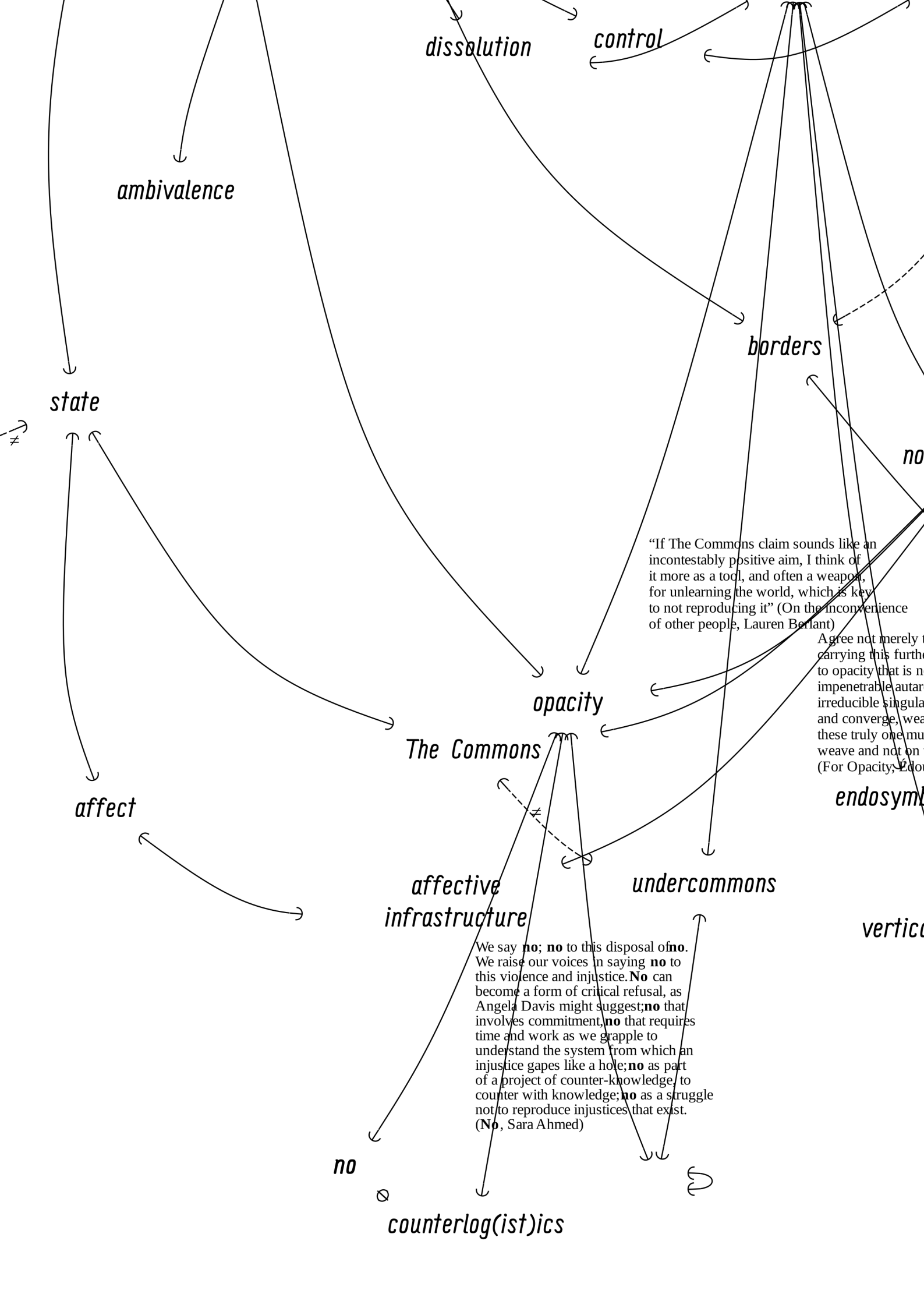

*ambivalence*

*dissolution*

*control*

*state*

*borders*

*no*

“If The Commons claim sounds like an incontestably positive aim, I think of it more as a tool, and often a weapon, for unlearning the world, which is key to not reproducing it” (On the inconvenience of other people, Lauren Berlant)

Agree not merely to carrying this further to opacity that is not impenetrable autarkic irreducible singular and converge, we are these truly one must weave and not on (For Opacity, Edouard)

*opacity*

*The Commons*

*endosymbiosis*

*affect*

*affective infrastructure*

*undercommons*

*vertical*

We say **no**; **no** to this disposal of **no**. We raise our voices in saying **no** to this violence and injustice. **No** can become a form of critical refusal, as Angela Davis might suggest; **no** that involves commitment, **no** that requires time and work as we grapple to understand the system from which an injustice gapes like a hole; **no** as part of a project of counter-knowledge, to counter with knowledge; **no** as a struggle not to reproduce injustices that exist. (**No**, Sara Ahmed)

*no*

*counterlog(ist)ics*



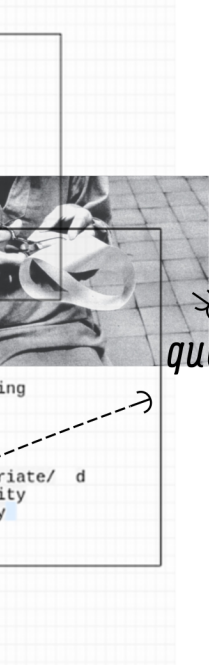

\*  
*queer angles*

“This is a rhythm of endurance, of surging forward and withdrawing. It is not a rhythm of endless becoming nor of staying put; it is making the most of the “hinge,” of knowing how to move and think through various angles while being fully aware of the constraints, the durability of those things that are “bad for us.”  
(Improvised Lives, AbdouMaliq Simone)

Queer ligatures: inclusive, non-binary, post-binary fonts, under construction. The fonts use the Queer Unicode Initiative (QUNI) to encode their inclusive glyphs and make their use compatible. (Bye Bye Binary)

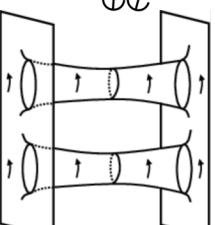
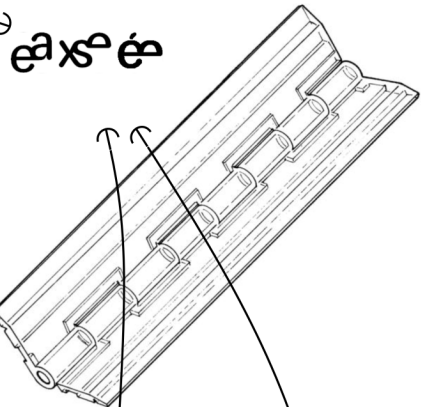

Lygia Clark, Caminhando [Walking] (1964)

*ea xº éþ*



Hein Bottle topology:  
side is outside is inside  
outside is inside is  
side is inside is outside  
inside is outside is inside

# insurgent intersectionality

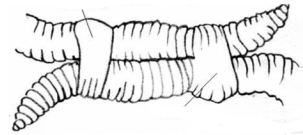
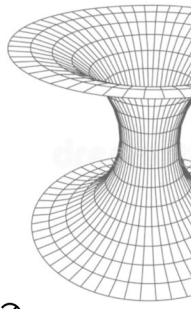

institutional  
manoeuvres

infrastructural  
manoeuvres

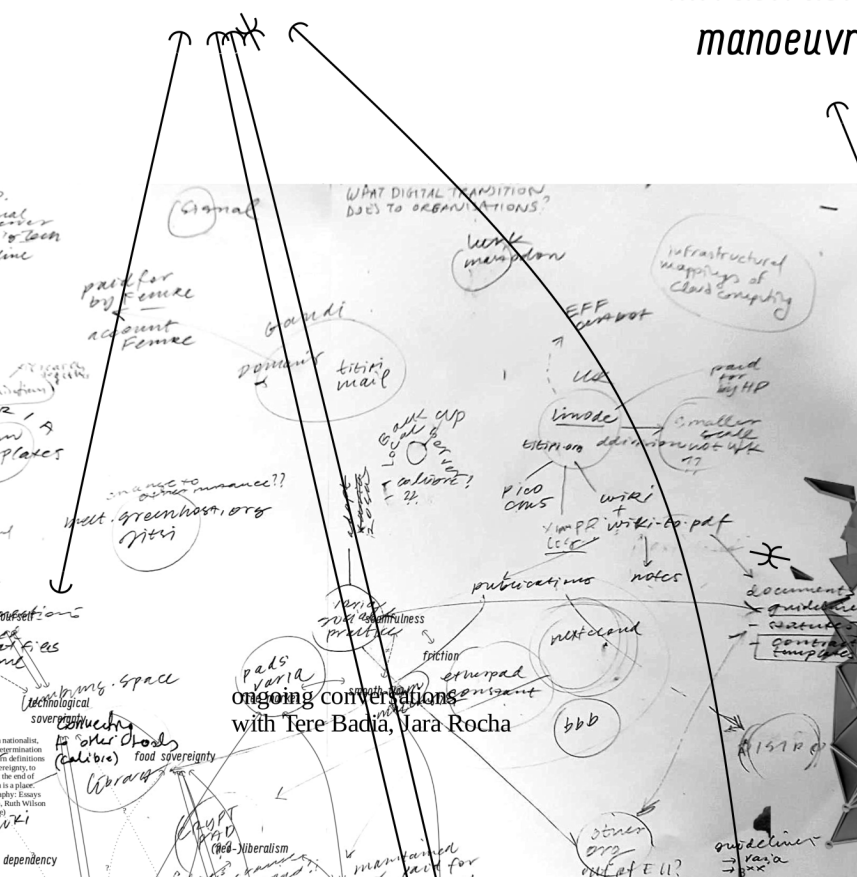

ongoing conversations  
with Tere Badia, Jara Rocha

maintenance

Paranodal is a term  
that which is other  
alternative to —  
configuration. (...  
the space that ne  
the negative spac  
noise between m  
(Zach Blas, Com  
Ulises Ali Mejia





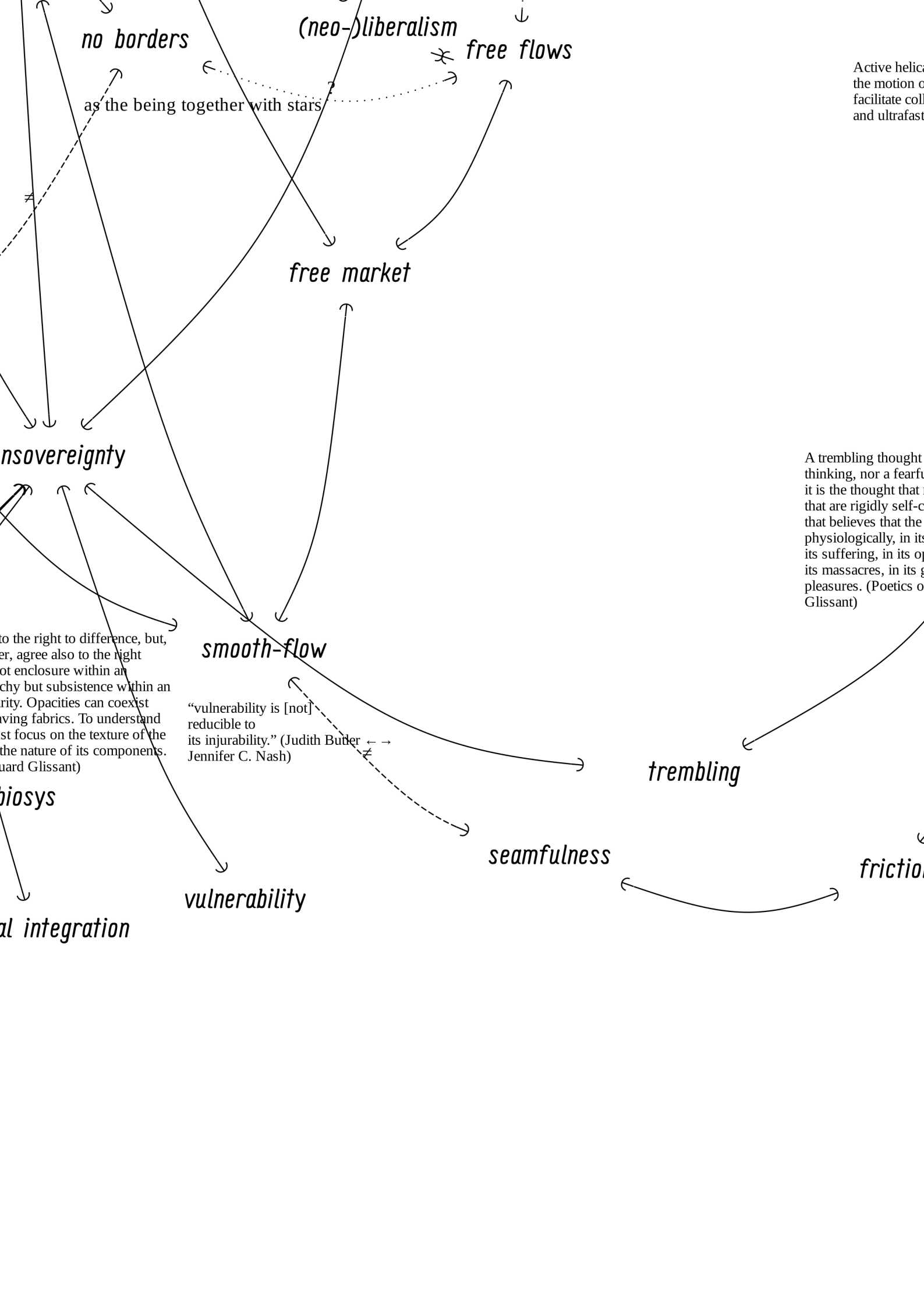





"In the wormhole the worm creates an infrastructure to hold itself in the world: the hole fits the worm, but only as it moves." (On the inconvenience of other people, Lauren Berlant)

*centralization*

"We might imagine re-turning as a multiplicity of processes, such as the kinds earthworms revel in while helping to make compost or otherwise being busy at work and at play: turning the soil over and over – ingesting and excreting it, tunnelling through it, burrowing, all means of aerating the soil, allowing oxygen in, opening it up and breathing new life into it" (Diffracting Diffraction: Cutting Together-Apart, Karen Barad)

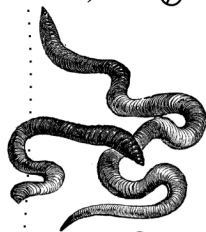

throwing worms at Paul Baran, On Distributed Networks (1964) (CCRURU)

form that conceptual  
er to — or an  
a network  
) the paranode  
works leave ou  
t of networks, t  
odes and edges  
tra-Internet ←  
s, Off the Network)

*horizontality*

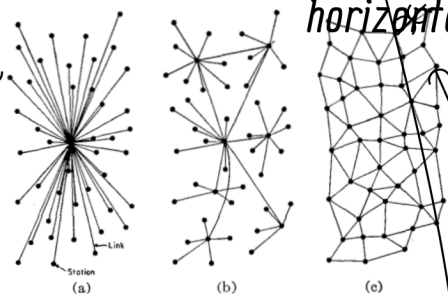
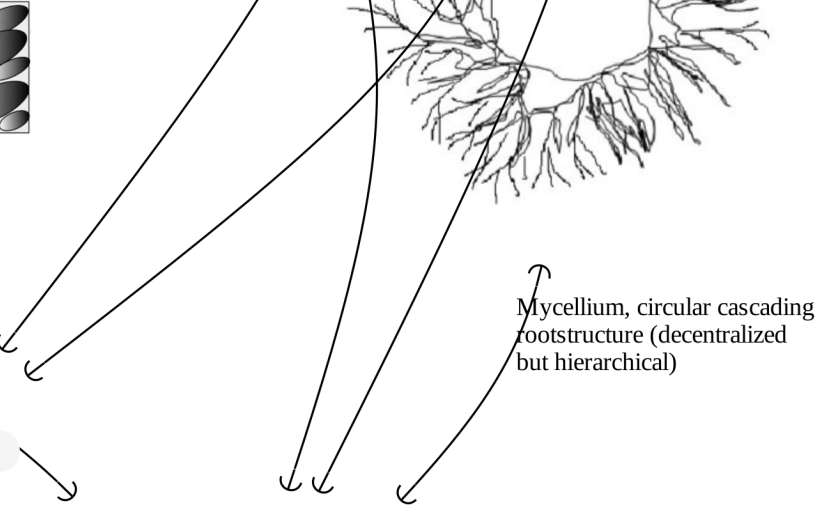

Fig. 1—(a) Centralized. (b) Decentralized. (c) Distributed networks.

*federation*

*imbrication*





# The Institute for Technology in the Interest of Worms

burrowing

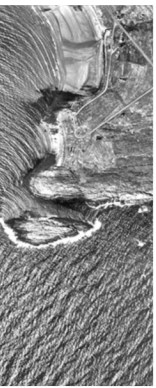
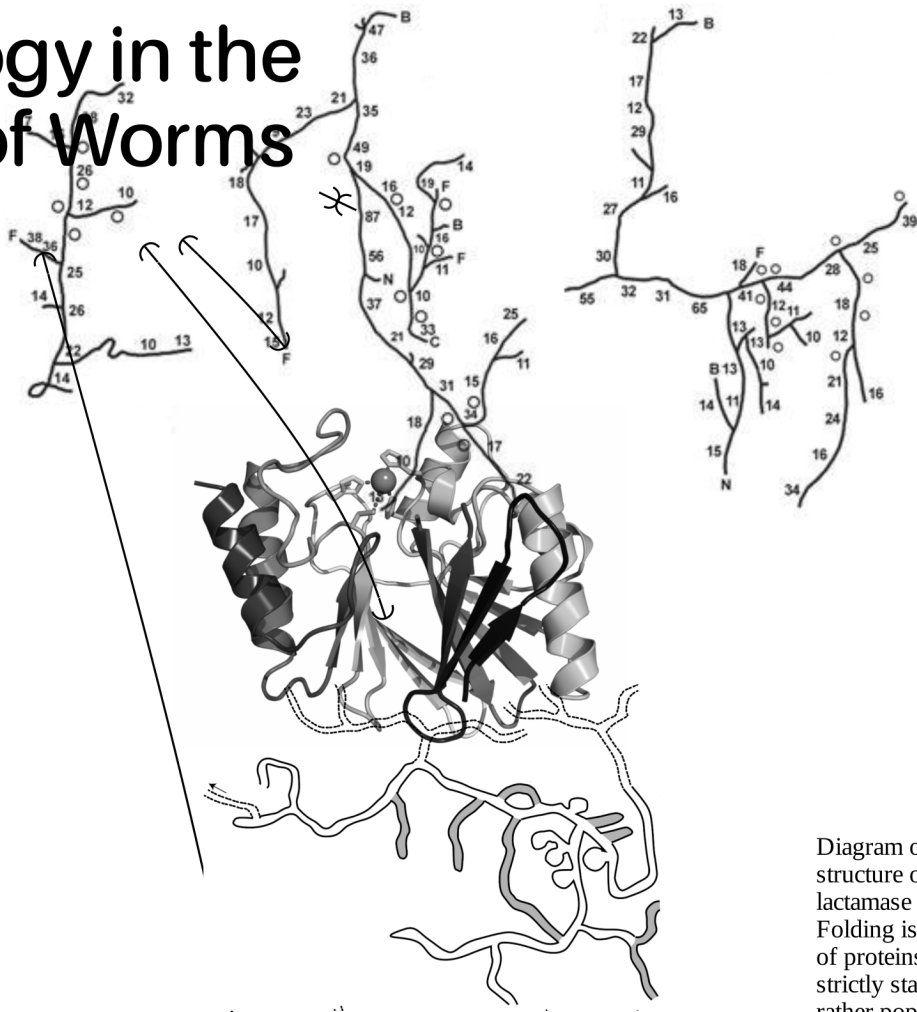
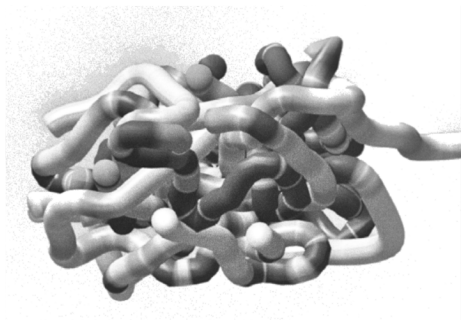

Diagram of the crystallographic structure of a zinc metallo-beta-lactamase from bacillus cereus. Folding is part of the dynamics of proteins. Proteins are not strictly static objects, but rather populate ensembles of conformations. Transitions between these states occur on a variety of time scales.

al waves produced by  
of individual worms  
lective tangling  
untangling.



is not a frightened  
al or hesitant one,  
refuses systems  
ontained, and  
world trembles,  
s becoming, in  
ppositions, in  
genocides, in its  
f relation, Édouard

*topological  
self-transformation*

n